



## SMS Metering Miniature Split Core Current Transformers

A range of miniature split core current transformers that offers a cost effective and efficient method by which the current can be measured without the need to break the conductor, each current transformer is supplied with colour coded leads of up to 3 meters for connection to the monitoring device. The MSC range of current transformers offers primary currents between 60-500A with 1 or 5A secondaries with class 1 accuracy performance. (Class 3 for 60-80A range).

### Specifications

System voltage	720V maximum
Test voltage	3kV for 1 minute
System frequency	50Hz or 60Hz
Primary ratings	60A to 500A
Short circuit thermal current	60 x rated primary current (Ith): for 1 sec
Overload withstand	1.2 x rated current continuously
Rated dynamic current	= 2.55 x Ith
Secondary leads	1A, (Length 3m), 5A (Length 1m) 2.5mm Wire
Enclosure	Flame retardant grade classified UL 94V-O
Aperture holes centres	18mm upto 250A, 28mm from 300A - 500A
Operating temperature	-20°C to +70°C
Accuracy Class	1, 3
Compliant with	IEC/EN 60044-1

### Features

- Cost effective moulded case
- Ratio's ranging from 60/1 to 500/5
- Fast Cable clamp connection
- Multiple fixing options
- Safety plug in shorting link

### Benefits

- Faster installation
- Compact size profile applications

### Accessories



Shorting link for safe installation, (CT will not operate until removed).



Fixing kit supplied



## Product Codes

Part number	Ratio	Class	Burden VA	Aperture	Lead length	Case	Wire colour	Dimensions H, W, D & A
MSC1-60/1	60/1	3	0.1	18mm	3m	Size 1	White S1 and Black S2	57.3, 31, 53, 18
MSC1-75/1	75/1	3	0.1	18mm	3m	Size 1	White S1 and Black S2	57.3, 31, 53, 18
MSC1-80/1	80/1	3	0.15	18mm	3m	Size 1	White S1 and Black S2	57.3, 31, 53, 18
MSC1-100/1	100/1	1	0.2	18mm	3m	Size 1	White S1 and Black S2	57.3, 31, 53, 18
MSC2-100/1	100/1	1	1	18mm	3m	Size 2	White S1 and Black S2	72.7, 44.5, 61.5, 18
MSC2-100/5	100/5	1	1	18mm	1m	Size 2	White S1 and Black S2	72.7, 44.5, 61.5, 18
MSC2-150/1	150/1	1	1	18mm	3m	Size 2	White S1 and Black S2	72.7, 44.5, 61.5, 18
MSC2-150/5	150/5	1	1	18mm	1m	Size 2	White S1 and Black S2	72.7, 44.5, 61.5, 18
MSC2-200/1	200/1	1	1	18mm	3m	Size 2	White S1 and Black S2	72.7, 44.5, 61.5, 18
MSC2-200/5	200/5	1	1	18mm	1m	Size 2	White S1 and Black S2	72.7, 44.5, 61.5, 18
MSC2-250/1	250/1	1	1	18mm	3m	Size 2	White S1 and Black S2	72.7, 44.5, 61.5, 18
MSC2-250/5	250/5	1	1	18mm	1m	Size 2	White S1 and Black S2	72.7, 44.5, 61.5, 18
MSC3-300/1	300/1	1	1.5	28mm	3m	Size 3	White S1 and Black S2	71.7, 44.5, 62.2, 28
MSC3-300/5	300/5	1	1.5	28mm	1m	Size 3	White S1 and Black S2	71.7, 44.5, 62.2, 28
MSC3-400/1	400/1	1	2.5	28mm	3m	Size 3	White S1 and Black S2	71.7, 44.5, 62.2, 28
MSC3-400/5	400/5	1	2.5	28mm	1m	Size 3	White S1 and Black S2	71.7, 44.5, 62.2, 28
MSC3-500/1	500/1	1	2.5	28mm	3m	Size 3	White S1 and Black S2	71.7, 44.5, 62.2, 28
MSC3-500/5	500/5	1	2.5	28mm	1m	Size 3	White S1 and Black S2	71.7, 44.5, 62.2, 28

### MSC1

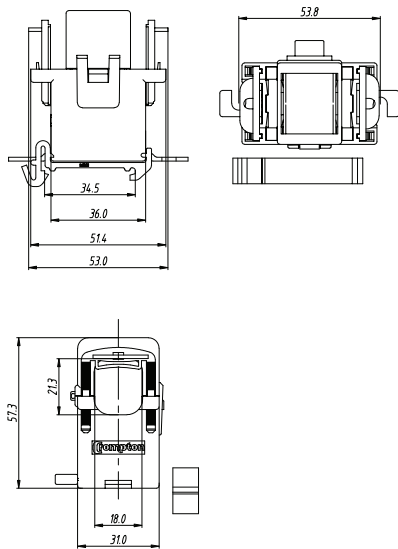

### MSC2

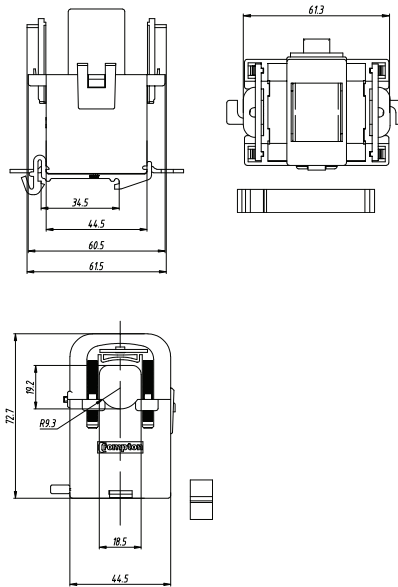

### MSC3

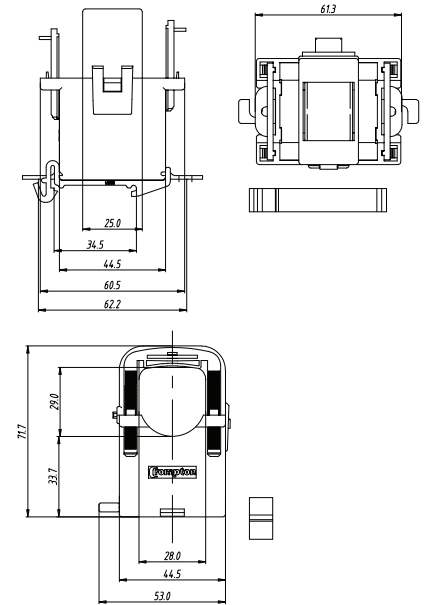

The supplier has made every reasonable effort to ensure the accuracy of the information in this catalogue and does not guarantee that it is error-free, nor does it make any other representation, warranty or guarantee that the information is accurate, correct, reliable or current. The supplier reserves the right to make any adjustments to the information contained herein at any time without notice. It expressly disclaims all implied warranties regarding the information contained herein, including, but not limited to, any implied warranties of merchantability or fitness for a particular purpose. The dimensions in this catalogue are for reference purposes only and are subject to change without notice. Specifications are subject to change without notice.



SMS METERING LTD

Tel: 0845 604 7244

Email: [info@smsmetering.co.uk](mailto:info@smsmetering.co.uk)

41 London Road, Castle Court, Reigate RH2 9RJ

[www.smsmetering.co.uk](http://www.smsmetering.co.uk)