



<b>kWh</b>	<b>kvarh</b>	<b>kVAh</b>	Active, Reactive and Apparent Energy
<b>BS</b>	<b>DIN</b>	BS / DIN housing	
			Multiple connection types
<b>CT</b>	Direct or current transformer connection		
<b>IP54</b>	Ingress protection		
	Load profile		
	Optical port		
	Real-time clock		
	Event log		
<b>RS485</b>	RS485 interface		
<b>tariff 4</b>	Multi-rate registration		
<b>MID B</b>	<b>IEC 1</b>	Accuracy class	
	Magnetic field detection		
	Photovoltaic ready		
<b>max</b>	Maximum demand		
	4 Quadrant measurement		

With a future-proof design the Polyphase MT174 is ready to suit many diverse customer requirements. High quality manufacturing process enables the meter to deliver the performance, expected in residential and small commercial environments. It includes a wide variety of functionalities:

- Extensive anti-tampering features
- Import/export energy management
- Photovoltaic friendly design
- RS communication interface
- Up to four tariff models
- Extended load profile
- Time-of-use (TOU) – internal tariffication



### Meter dimensions

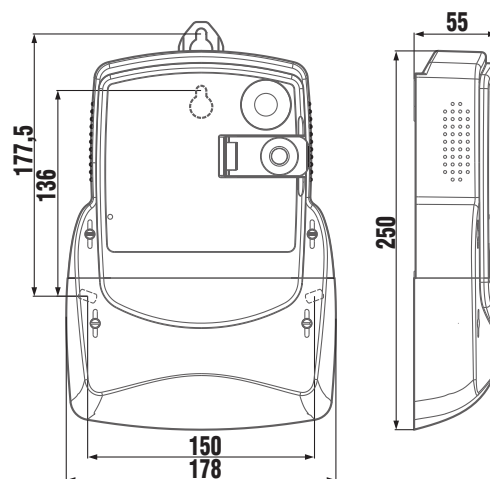

## Type overview

		MT174-D1 BS	MT174-D1 DIN	MT174-D2 BS	MT174-D2 DIN	MT174-T1 CT
<b>Network</b>	Low voltage	●	●	●	●	●
<b>Connection type</b>	3P2W	●	●			
	3P4W			●	●	●
<b>Communication</b>	RS485	●	●	●	●	●
	Optical port	●	●	●	●	●
<b>Input – output options</b>	Output S0	●	●	●	●	●
	Output OPTOMOS	●	●	●	●	●
	Tariff input (1 or 2)	●	●	●	●	●

## Technical specifications

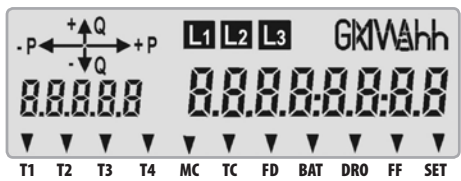
		MT174-D1 BS	MT174-D1 DIN	MT174-D2 BS	MT174-D2 DIN	MT174-T1 CT
<b>Nominal voltage</b>	$U_n$	3x230/400 V, 3x230 V, 230 V, 3 x 400 V				
<b>Voltage range</b>		0.8 – 1.15 $U_n$				
<b>Reference frequency</b>		50 Hz or 60 Hz				
<b>Current</b>	Base current $I_b$	5A or 10A				1 A
	Starting current $I_{st}$	5A => Class 2: 0.025A, Class 1: 0.02A 10A => Class 2: 0.05A, Class 1: 0.04A				20 mA
	Maximal current $I_{max}$	85 A, 100 A, 120 A				6 A
<b>Accuracy class</b>	Active energy	Class 2 or Class 1 A or B (EN 50470 - 3, IEC 62053-21 or -23)				
	Reactive energy	Class 3 or Class 2				
	Apparent energy	Class 3 or Class 2				
<b>Real-time clock</b>	Accuracy	Better than $\pm 3$ min/year at 23 °C				
	Back-up power supply	Li battery: 5 years, life time up to 20 years				
<b>Temperature ranges (IEC 62052-11)</b>	Operation	-40 °C ... +60 °C; extended -40 °C ... +70 °C				
	Storage	-40 °C ... +80 °C				
<b>Ingress protection IEC 60529</b>		IP54				
<b>Liquid Crystal Display</b>						

## Basic functionality

### Measurement features

- Two way (“energy”) measurements
- Active, Reactive and Apparent energy and demand in 3-phase 4- and 3-wire networks
- Measurement by phases and polyphase, quantities of measurement: Voltages by phases, Currents by phases, Power factors by phases, Frequency
- Measurement of instantaneous power

### Tariff functions

- Time-of-use (TOU) measurement of active energy and maximum demand (up to 4 tariffs, 10 seasons, 10 weekly programs, 10 daily definitions, 10 tariff change over inside individual daily tariff programs, 46 holidays)

### Load profiles

- Load profile recorder with up to 8 channels
- Possibility to set the recording period on 5, 10, 15, 30, 45 or 60 minutes

### Communication

- IEC 1107 compliance
- Two communication interfaces:
  - Optical port
  - RS485

### Real-time clock (RTC)

- Compliant with IEC 62054-21 standard
- RTC with calendar, based on 32 kHz quartz crystal
- RTC accuracy: better than  $\pm 3$  min/year, operation reserve: 5 years, expected Li battery life time: 20 years
- Counter of elapsed time of RTC operation
- Li battery enables data display on LCD when meter is in no-power state

### Specifics

- Backlit LCD display
- Detection of opening main and terminal cover
- External magnetic field detector
- Detection of meter wiring
- Photovoltaic ready
- Secured communication channels
- Load profile on LCD
- Change of set parameters protected with a sealed pushbutton
- Indication of low Li battery

SMS Metering Ltd - SolarCorner  
 41 London Road, Castle Court, Reigate RH2 9RJ  
 T: 0845 604 7244  
 E: info@smsmetering.co.uk  
 W: www.smsmetering.co.uk



Iskraemeco, Energy Measurement and Management  
 4000 Kranj, Savska loka 4, Slovenia